



education

Department:
Education
REPUBLIC OF SOUTH AFRICA

TECHNOLOGY

Common Tasks for Assessment

Grade 9

2007

SECTION B

TEACHERS GUIDE

Memorandum

🕒 Time: 2 hours

✓ Marks: $80/2 = 40$

📄 No. Pages: 13

Learning Outcomes and Assessment Standards addressed in this Formal Assessment Task are given in the table below:

Question 1	
Learning Outcome	Assessment Standard
LO1	Investigates – analyses existing products relevant to an identified need in terms of safety and fitness for purpose
	Designs – chooses possible solution based on well reasoned argument
Question 2	
LO1	Investigates – analyses existing products relevant to an identified need in terms of suitability of materials
LO2	Processing - recycling
LO3	Impact of technology – strategies for reducing undesirable effects
Question 3	
LO2	Mechanical Systems & Control – gear systems
Question 4	
LO2	Mechanical Systems & Control – belt drives and gear systems
Question 5	
LO1	Designs
Question 6	
LO2	Structures – analysis of the effects of different loads and knowledge of structural components
Question 7	
LO2	Electrical Systems & Control – how simple electronic circuits and devices are used to make an output respond to an input signal
Question 8	
LO1	Design – identify the problem based on all the design key words (purpose, access, age, target market, safety, environment where the product will be used)
	Investigates – analyses an existing (design for a) product relevant to an identified need or opportunity in terms of safety and fitness for purpose
	Evaluates – the plan and demonstrates insight into the consequences of key decisions and suggest sensible improvements
LO3	Impact – recognises and identifies the impact of a technological development (design) on the quality of people’s lives and suggests strategies for reducing undesirable effects.

Question	Marks
Questions 1	15
Questions 2	9
Questions 3	7
Questions 4	6
Question 5	11
Question 6	12
Questions 7	12
Questions 8	8
Total	80/2= 40 Marks

Question 1

1. In a remote village deep in rural South Africa, there lives a little boy called Mbulaheni. He is well-liked by everyone even though he never participates when the others play soccer, nor does he help when the boys herd the village cattle into the kraal. The problem is that Mbulaheni cannot walk. Since the village is far from the nearest clinic, no one has been able to obtain a wheelchair for him. His friends decided to design and build a wheeled cart so that they will be able to help him to participate in their fun and games.

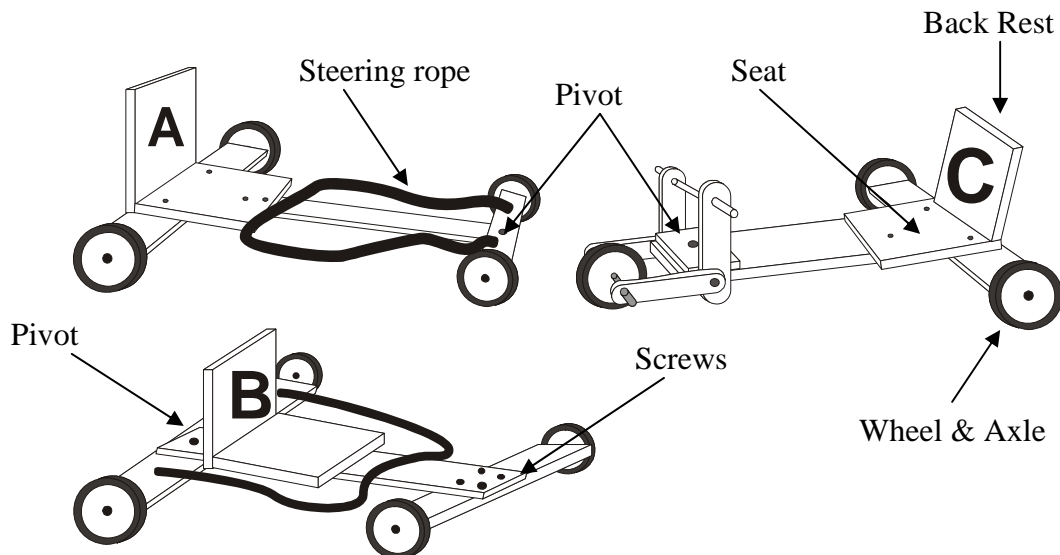

Look carefully at the designs they drew before selecting the best one to build. Answer the questions below.

1.1. Compare A and B: In what way(s) are they different?

<i>A is front-wheel steering, while B is steered by the rear wheels ✓✓</i>	2
--	---

1.2. Compare A and C: In what way(s) are they the same?

<i>Both A and C are steered using the front wheel ✓✓</i>	2
--	---

1.3. Look at the steering mechanism of the three carts. Which one of the carts is more easily steered than the other two? Circle one ✓ **(A)** B C

Give two **valid reasons** for your choice: [Any two]

<i>A - The rope is easy to reach, and the steering is intuitive/natural ✓✓</i>	1+4
<i>B - Rear-wheel steering is unnatural/ counter-intuitive ✓✓</i>	
<i>C - C the handlebar is out-of-reach, there will be lots of friction ✓✓</i>	

1.4. Compare the **stability** of all three carts. Which one is **least stable** and, therefore, most likely to turn over? Circle one ✓ A B **(C)**

Give a **valid reason** for your answer:

<i>C has only three wheels ✓</i>	1+1
----------------------------------	-----

1.5 Choose the cart that you think is best overall design Circle one **(A)** B C

Circle the letter of the best cart from the following criteria:		
Safety	Circle one (A) B C	1
Fit-for-purpose	Circle one (A) B C	1
Aesthetics	<i>Any one ✓ - subjective</i> Circle one A B C	1
TOTAL		15

Question 2

Recycling and remanufacturing is the process where used materials are broken down and made into something useful. This is especially important to help sustain non-renewable resources. Most items for recycling must be sorted into categories before meaningful recycling can be done.



2.1 Below is a list of “waste” items often thrown away. Sort them into the correct category for recycling by ticking the correct column for each item.

	Paper	Plastic	Metal	Glass	Plant Matter
Potato peels					✓
Newspaper	✓				
Tins			✓		
Grass clippings					✓
Plastic bags		✓			
Egg boxes	✓	OR ✓			
500ml cooldrink bottle		✓			
Yogurt cups		✓			
TOTAL: 8 ÷ 2					4 Marks

2.2 Properly sorted waste material needs to be further sorted into sub-types for recycling to be possible. Paper, metal and plastics are sorted into different grades and types of material at the start of the recycling process.

Metals and Plastics need to be sorted according to type before they can be recycling.

2.2.1 How can metals like iron and steel be easily sorted from metals like copper and aluminium? Suggest an easy two ways to do this.

Iron & steel are magnetic, while copper and aluminium are not ✓. Use a magnet to attract the iron/steel ✓, leaving the copper and aluminium behind ✓.

Aluminium and copper can then be separated by colour or by weight ✓ **4/2=2**

2.3 Sort the following plastic items into the correct category for recycling by ticking the correct column for each item.

In response to this question you may refer to Section A

Type of Plastic	PET	PE-HD	PVC	PE-LD	PP	PS
Plastic bucket		✓				
Plastic cups					✓	
Cooldrink bottles	✓					
CD Cases						✓
Plastic plumbing pipes			✓			
Take-away food containers						✓
: 6 ÷ 2					3 Marks	
TOTAL					Marks 9	

A shop keeper needs a display for a new product.

The purpose of the display is to show the new product in an unusual manner to attract the attention of the people.

The display will be placed on the counter of the shop.

The figure below is an example of a display.

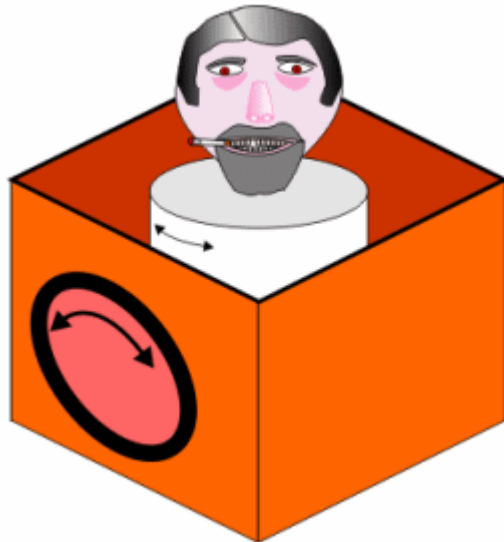

(Illustration from: www.technologystudent.com)

Sketch a possible design idea to present to the shopkeeper. You can make use of any **mechanical system** studied in Grade 8 or 9. The sketch must be drawn so that the **mechanical system can be seen**.

Make sure the following aspects are covered in your design:

- Select any **suitable product** to display and **label the product**. (1)
- The model of the design must be **hand operated**. (1)
- The display must be able to **move**. (1)
- Use any suitable **Three Dimensional (3D)** sketch to show your design. (3)
- **Label the mechanical components** used in your design (2)
- Present a **systems diagram** for the design of your mechanical display. (3)
(Describe the input, process and output under these given headings)

The **design** and **presentation** must be different to the example given.

You will be credited for using your own ideas and not just copying from the example given above

ANSWER SHEET FOR QUESTION 5

Use the mark allocation below to award marks using your professional judgement

Mark Allocation for Question 5:	Mark allocated	Mark gained
1. Suitable product is selected and labelled	1	
2. Suitable hand operated design	1	
3. Suitable movement is used	1	
4. Suitable 3D Sketch	3	
5. Mechanical components are accurately labelled	2	
6. Accurate systems diagram presented	3	
Total:	11	

Question 6

Here are photographs of the Aloe Cove Dam across the Crocodile River in the Cradle of Humankind, Gauteng. It can be found at the Haia Safari Lodge.

This dam was built in 5 years by a small team of men working without machinery. The wall is 6m high and 240m across, and is built from natural stone and cement.



The above view shows the lake being held back by the structure of the dam



The above view from the downstream show the large mass structure which holds back the force of the lake, which is 4 km long.

- 6.1 Look at the photograph and **identify the two main structural features** that make up the dam wall.

The wall is made up of **arches** ✓ and **buttresses** ✓

2

- 6.2 Use the sketch below to show how the structure of the wall disperses the force of the water pushing against it. Use **arrows** to represent the forces acting on the wall, and the effect of the wall shape on these forces. ✓✓✓✓✓

5

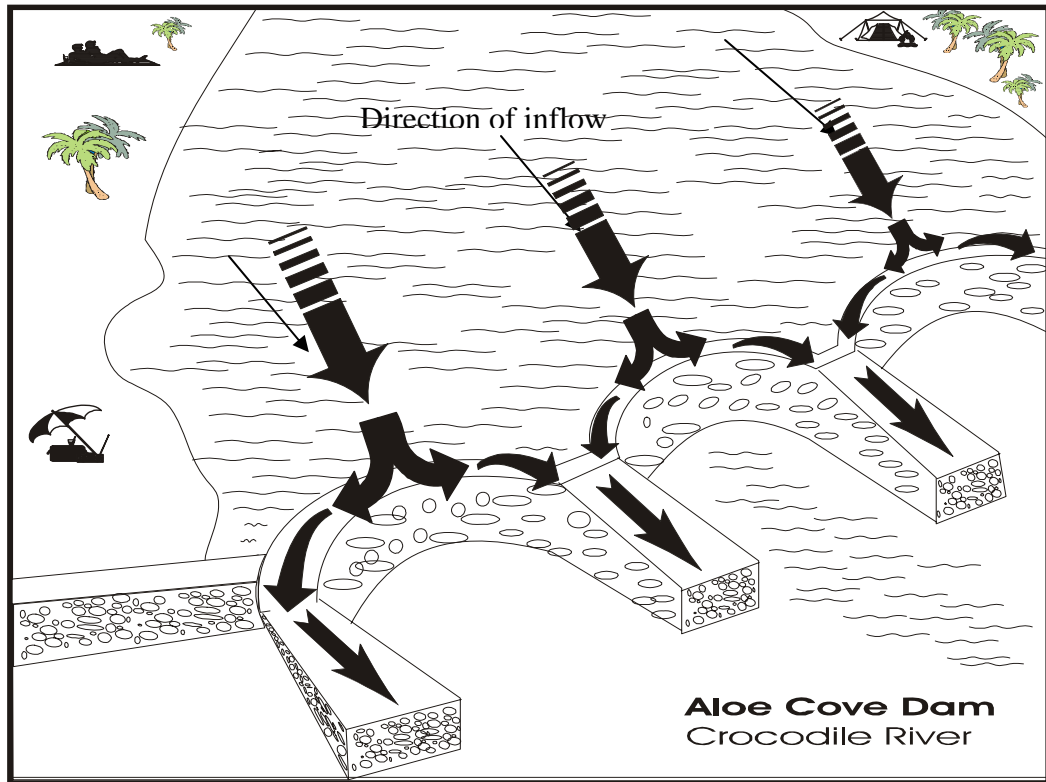

6.3 Explain why you think the dam wall took five years to build. [3]
 Refer to the following aspects: *choice of materials, construction methods, labour.*







Rough stone is difficult to build with	✓
Manual labour without machinery is slow	✓
Small labour force delayed construction	✓

6.4 Describe one possible positive and one negative impact that the construction of the dam wall may have had on the environment during the five years it took to build:

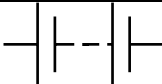
Negative:	Removing stone could cause erosion ✓	[1]
	OR river water could be polluted by mud	
Positive:	Lack of machinery did less damage to the river banks ✓	[1]
	OR Jobs were created for the builders (<i>economic environment</i>)	
Total		12

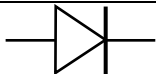
QUESTION 7 SYSTEMS AND CONTROL: ELECTRONIC

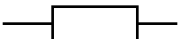
The table below provides symbols for a selection of electronic components. Each component is named and the use of each component is described. Use the information in the table and answer the questions that follow.

SELECTION OF ACCEPTABLE CONVENTIONS FOR ELECTRONIC COMPONENTS		
SYMBOL /CONVENTION	NAME / DESCRIPTION	USE
	Single cell	Energy source – often 1,5 volts
	Battery (two or more cells)	Energy source
	Switch (open position)	Device to open or close a circuit
	Diode	Process device that allows current flow in one direction only
	Light Emitting Diode L.E.D.	Output device which emits light when small current passes through it
	Capacitor	Process device that can store an electric charge
	Resistor	Process device that restricts the electric current
	Buzzer	Process device that converts electric energy into sound energy

7.1	Draw a circuit diagram for a working electronic device that makes use of the following electronic components: A 6 volt battery, a light emitting diode, a switch and a resistor.	[4]
-----	---	-----

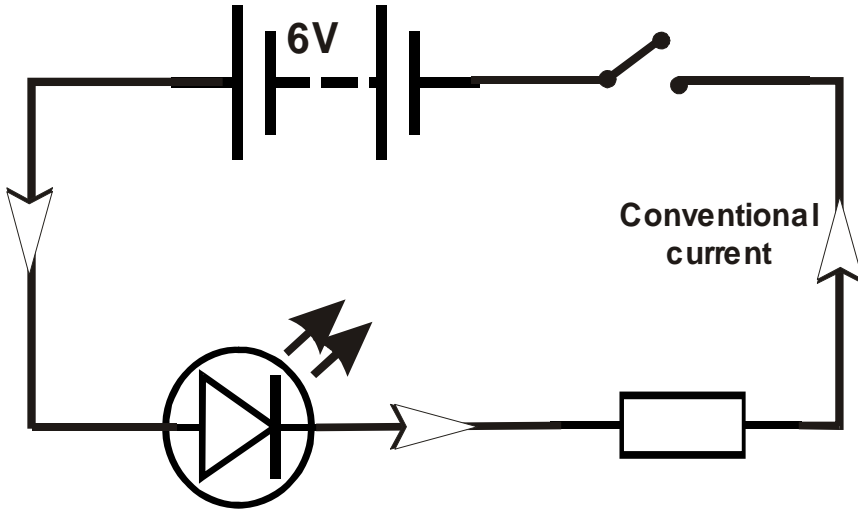

NOTE:

The order of the components is not important. Learners must draw a series circuit, the switch can be open or closed and anywhere in the circuit. The LED must face in the direction of the conventional current.

7.2	Use arrows to indicate the direction flow of the conventional current on the circuit diagram you have drawn. See on drawing ✓	[1]
-----	--	-----

7.3	What is the importance of the resistor in the circuit? The resistor protects the LED from the current supplied by the six volt battery ✓	[1]
-----	--	-----

7.4	Describe a product you could design and make that will use the electronic circuit you have drawn. Describe how you would adapt the electronic circuit you have drawn to accommodate a person who is deaf or hearing impaired.	[2]
	People with hearing disabilities cannot hear door bells so we need to substitute the bell with a visual output device e.g. a LED or a light bulb	
	✓✓	

7.5	Mpho has a house with a front and a back entrance. She wants to set up two push-button switches (one at the front door and one at the back) so that visitors will be able to ring the doorbell no matter at which door they are standing. Draw a circuit diagram that will allow Mpho's visitors to ring her doorbell from either of the two entrances. Your diagram should show the following components, correctly connected: A 3V series battery; one buzzer, two push buttons [one for the front door; one for the rear door]	[4]
-----	--	-----

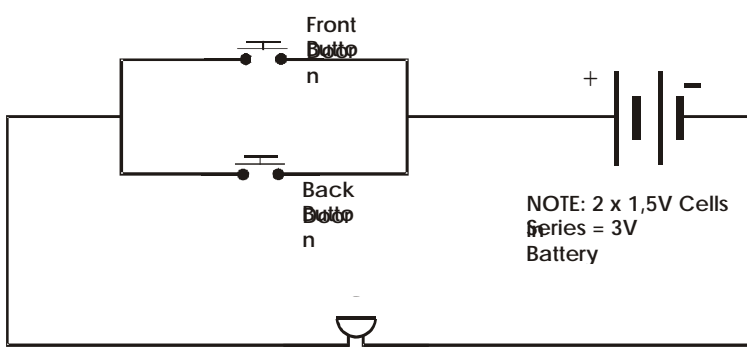

The circuit needs to have two switches connected in parallel ✓✓ – this is called an OR Gate (learners do not need to state this). The 2-cell series battery provides 3V P.D. The buzzer is connected in series. ✓

Total

12 marks

Question 8

STRUCTURES DESIGN PROBLEM

[8]

South Africa has been awarded the Soccer World Cup in 2010. Currently many programs have started preparing the stadiums for the big event. Soccer City has called for designs for a special section of the main grandstand to be upgraded specifically to cater for elderly and disabled spectators. The design calls for a ramp for wheelchairs, and suitable stairs for elderly people to be able to use in comfort.

Here is a design submitted by a hopeful contractor. Unfortunately, the design is poor and should be rejected.

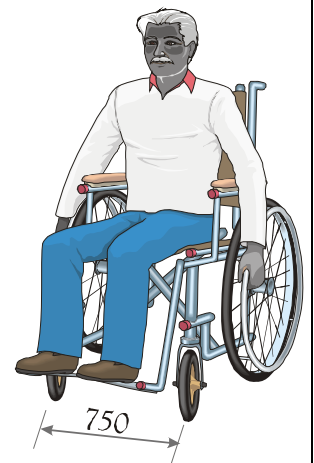
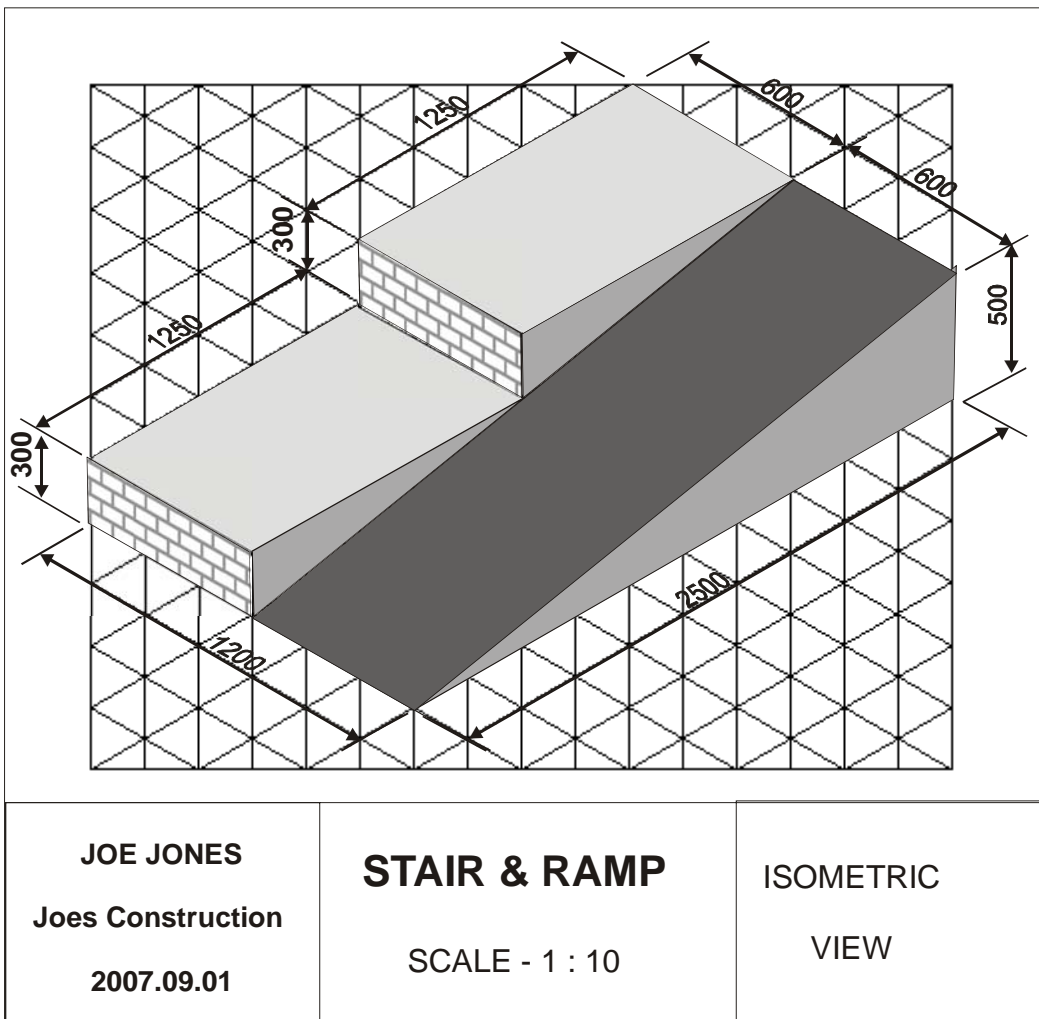

8.1 List any **four** problems with the design

[8]

ANY FOUR

▪ The ramp is too narrow (600mm) for a wheelchair (750mm) ✓	[2]
▪ The ramp is too steep – 5:1 slope ✓	[2]
▪ The step riser (300mm) is too high for elderly or other physically challenged people ✓	[2]
▪ There are no handrails to assist physically challenged people ✓	[2]
▪ There is nothing to prevent wheelchairs from running off the ramp ✓	[2]
Total	2X4 = 8 Marks

TOTAL: 80 MARKS