



education

Department:
Education
REPUBLIC OF SOUTH AFRICA

**COMMON TASK FOR ASSESSMENT (CTA)
GRADE 9 – 2008**

TECHNOLOGY

LEARNER'S BOOK

SECTION A

THEME:
Water for Life

Suggested Time: 5 hours

150 marks

Number of pages: 3

ANSWER ALL QUESTIONS IN THE ANSWER BOOKLET PROVIDED

CONTENTS

| Task/ Activity | | LOs and ASs | Time/ min | Mark | Pg | Resources |
|---------------------------|---|----------------------------------|----------------------|-------------|-----------|--|
| | Note to learners | | | | 3 | |
| TASK 1 | Case Study | LO2 AS2 LO2 AS3 LO3 AS2 | 30 | 20 | 3 | |
| TASK 2 | Investigation of mechanical control systems | LO1 AS2 LO1 AS15 LO2 AS3 | 40 | 24 | 5 | Grade 9 Technology text books, library books, Internet, ruler, pencil and eraser. |
| TASK 3: | Increasing production with irrigation | | | | 6 | |
| Activity 1 | Design brief, specifications, constraints | LO1 AS5 LO1 AS6 | 20 | 12 | 6 | |
| Activity 2 | Design | LO1 AS7 LO1 AS15 | 20 | 12 | 8 | Ruler, pencil and eraser. |
| Activity 3 | Selection of design | LO1 AS8 | 20 | 6 | 9 | |
| Activity 4 | Make: planning | LO1 AS8 LO1 AS9 | 40 | 34 | 9 | Ruler, pencil and eraser. |
| Activity 5 | Make | LO1 AS10 LO1 AS11 LO1 AS12 | 70 | 20 | 11 | Tools, equipment and materials for making model (e.g. rope, string, glue, cardboard, wire, dowel sticks, masonite, 3-ply, Perspex, hard board, scissors, craft knives, wire snips, pliers, hacksaws. |
| Activity 6 | Evaluates the product | LO1 AS13 LO1 AS14 | 60 | 22 | 12 | |

NOTES TO LEARNERS

- You will work in groups of 4 – 6.
- All group work activities must be completed in class time.
- Make sure that all questions are answered neatly in the Answer Booklet.
- There is a glossary on page 11 explaining words you may not understand.

TASK 1: CASE STUDY INDIVIDUAL ACTIVITY

(30 minutes)

LO 2: AS 2, AS 3; LO 3: AS 2

Marks: 20

Read the case study below and then answer the questions that follow. You will be assessed on your ability to explain how different cultures use technological solutions, and to identify the impact of technological development on the quality of people's lives and on the environment.

THE TREADLE PUMP

In countries which are affected by drought, like Zambia, it is important for people to be able to produce food all year round. To do this they have introduced technologies to make the best use of available water resources. A very simple and inexpensive water lifting device that is used there is the treadle pump. This has made millions of the world's poorest farmers in developing countries double their incomes. By using this device, farmers in these countries are able to harvest a second or third crop in the dry season as well as plant new varieties of vegetables. In some cases, crops are being grown where nothing grew before.



A woman operates a bamboo treadle pump in Nepal.
Courtesy of Winrock International

The treadle pump costs less to buy and operate than a motorised pump. It is a lever device designed to lift water from rivers, lakes and boreholes. Pumping is achieved by standing on the two treadles connected to pistons in the cylinder. By shifting the human body weight from side to side, the pistons in the pump cylinders are activated up and down. The pump discharges water on the downward movement of the pistons by pressurizing it through the manifold to the outlet pipe. In this way, water can be lifted to a height of up to 8 metres.

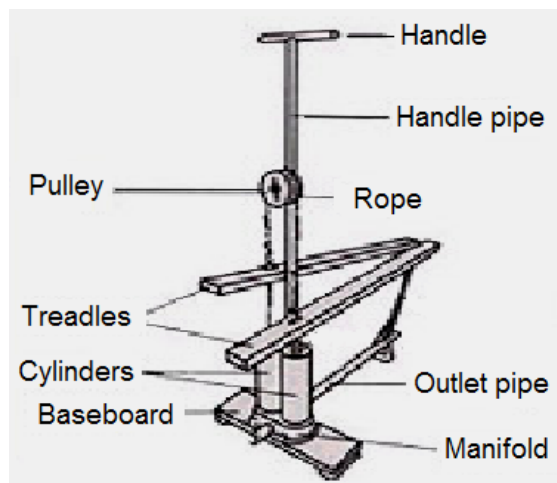

Perspective drawing of a treadle pump
 <www.aovinternational.com/gifs/treadle-pumps.jpg>

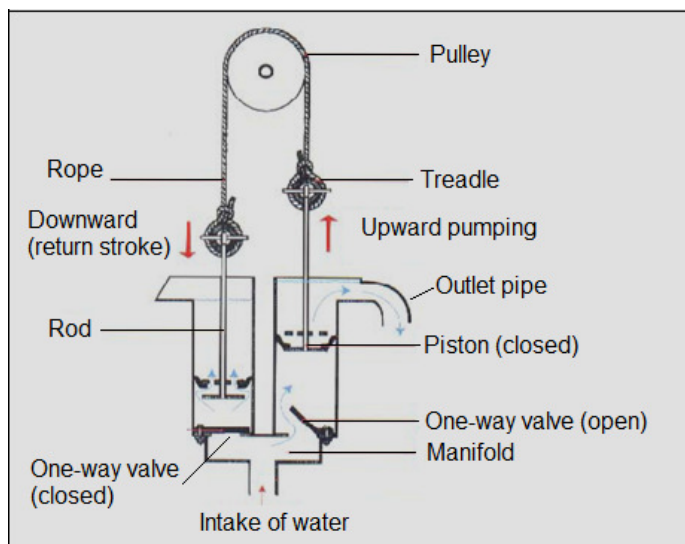

Cross-section view of a treadle pump
 <www.wca-infonet.org>

The treadle pump is made of locally available materials (i.e. scrap yard metal, wood and animal skin) which make it inexpensive and affordable for the small-scale poor farmer. The treadle pump has been designed and manufactured in such a way for any farmer to be able to use it and maintain it.

While the pump can last up to seven years, the internal movable parts (i.e. the rubber cups for the piston and the rubber flaps for the one-way valve) can last from 9 to 18 months, depending on the use and source of water. We have learnt that sandy and muddy water will wear out the rubber cups in just a few weeks.

In order to increase the *lifespan* of the internal moveable parts, it is recommended that a strainer is used at the point where water comes into the pump. This will stop any debris coming into the pump. When the one-way valves (i.e. the rubber flaps), which allow water to flow one way only into the pump, wear out, they can easily be replaced by using old bicycle or motor vehicle tubes. The nylon rope which moves over the pulley may also break, but animal skin hides, old bicycle chains and old fan belts can be used to replace this rope. The wooden treadles can be made from any wood found in the village, provided a carpenter drills holes in the correct places. This makes the treadle pump easy to maintain.

Questions:

- 1.1 The introduction of the treadle pump into Zambia has affected the quality of life of the local people. Give TWO ways in which local farmers can increase their harvest by using the treadle pump. (2)
- 1.2 Why are treadle pumps better for the environment than motorised pumps? (1)
- 1.3
 - 1.3.1 Name a mechanical control mechanism used in the treadle pump. (1)
 - 1.3.2 What is this mechanism's purpose when used in a treadle pump? (1)
 - 1.3.3 What material is this mechanical control mechanism made from? (1)
 - 1.3.4 How can local farmers replace this part when needed? (1)
 - 1.3.5 Is this re-using, recycling or re-manufacturing? Motivate your answer. (2)

- 1.4 In point form, list **THREE** advantages of the treadle pump. (3)
- 1.5 Name a disadvantage of the treadle pump. (1)
- 1.6 1.6.1 What is meant by *lifespan*? (1)
- 1.6.2 Give **ONE** way in which Zambian farmers are able to increase the lifespan of the treadle pump. (1)
- 1.6.3 In a short paragraph, discuss the impact that the treadle pump can have on the lives of poor farmers and the environment. Is the impact generally positive or negative? Give reasons for your opinion. (5)

**TASK 2: INVESTIGATION OF MECHANICAL CONTROL SYSTEMS
INDIVIDUAL ACTIVITY**

(40 minutes)

LO 1: AS 2, AS 15; LO 2: AS 3

Marks: 24

This activity requires you to demonstrate your research and investigation skills as well as your communication skills. You need to keep this information as it will assist you in Activity 4.

Find out about the following mechanical control systems by using school text books, library books and/ or the internet:

- pawl and ratchet;
- one-way valves; and
- cleats, including cam-cleats.

You need to find out:

- what the purpose of each of these mechanical control systems is;
- how they work;
- where they are used in real-life situations.

- 2.1 Draw a sketch of each mechanical control system. Use headings and labels to show the parts of each system. (18)
- 2.2 Under each drawing, give the purpose of each mechanical control system and give an example of where it is used in real life. (6)

TASK 3: INCREASING PRODUCTION WITH IRRIGATION**ACTIVITY 1: DESIGN BRIEF, SPECIFICATIONS, CONSTRAINTS****INDIVIDUAL ACTIVITY****(20 minutes)****LO 1: AS 5, AS 6****Marks: 12**

This activity assesses your ability to analyse a problem by developing a design brief, constraints and specifications. Read through the scenario as it sets the scene for the challenge. Then read through the challenge carefully so that you understand your task.

Scenario**Farmer Increases Production with Irrigation and Better Planting Techniques**

'A clear vision, a bit of help, a little luck, a few tips, a lot of water, and a lot of hard work' - that's Moussa Sagna's recipe for success as a market gardener. His grand plans are already taking root. Sagna speaks softly, but quickly and with intensity. A true man of the soil, he tills his plot in Djifanghor, a village of about 2 000 people near the southern Senegalese town of Ziguinchor. He is serious about his work. Produce from his land helps feed his two wives and seven children, aged 1 to 12. The oldest children are now in school.

His motto: 'If you work in large quantity, you eat, you buy, and you save.'



Moussa Sagna on his farm
Photo Credit: Richard Nyberg/ USAID

Only three years ago he was still a small-time farmer, surviving on a 150 square metre (150m²) plot as part of a new farm shared by 66 others. Today, he has nearly tripled the size of his land to 400 square metres (400m²) by being able to take over some family land outside the farmers' group area.

(Adapted from 'Agriculture, Economic Growth', 2005)

THE CHALLENGE

3.1 Design Brief:

Sagna needs to lift water from the river to his lands for irrigation purposes. The river is 1m below his land. He needs to get the water up the river bank into a storage tank next to his fields.

You work for an NPO (non-profit organisation) that assists rural farmers by providing sustainable water supplies. A team of technologists are designing a device to assist Sagna to lift water from the river to his storage tank. This device uses a hand-operated pulley-and-rope system to lift water from the river in buckets, up the river bank and into Sagna's water tank. The pulley-and-rope system will enable the buckets, when filled with water, to be lifted with less effort. Your task is to design a cam-cleat to stop the buckets from falling back downwards once they have been lifted up. You need to make a model to demonstrate your cam-cleat to the rest of the team. The cam-cleat needs to keep the rope tight to stop the buckets from falling back.

Discuss and write the design brief for your task. Your brief should be a short, clear statement showing what you have to make. It also needs to state who will be using the final product, its purpose and where, in general, it will be used. (3)

3.2 Constraints:

List TWO constraints that you will have to consider when designing and making this mechanical control system. A constraint is a factor that will limit your choice when designing. (2)

3.3 Specifications:

The specifications must refer to the final product that Sagna will use and not the model. You need to choose SEVEN of the following aspects that are relevant to the final product and then expand on these aspects.

- who the product is for (the target market)?
- where the product will be used?
- what the product will do (purpose)?
- the appearance and aesthetics: form, colour, shape, texture, size;
- the environmental impact: short- and long-term effects of the materials and the product itself;
- the social impact: will your product be beneficial or have a negative impact on certain people or communities;
- safety aspects for the users;
- cost of materials;
- ergonomics: ease and comfort of use. (7)

**ACTIVITY 2: DESIGN
INDIVIDUAL ACTIVITY**

(20 minutes)

LO 1: AS 7, AS 15

Marks: 12

This activity assesses your ability to think creatively by developing a solution and to communicate effectively using free-hand sketches.

- 3.4 Decide on an initial idea of a clam-cleat for the model. Draw neat free-hand sketches. Keep in mind the constraints and specifications that you have developed. Add necessary notes and labels to make your idea clear to anyone looking at your drawing.

Next to your sketches, list the strengths and weaknesses of your idea according to the constraints and specifications that you have developed. (12)

Rubric to assess Activity 2: Design

| LEVEL | DESCRIPTORS | MARKS |
|-------|---|--------|
| 6 - 7 | <ul style="list-style-type: none"> • Develops a creative, relevant idea by drawing neat freehand sketches taking into consideration the design brief, constraints and specifications. • Comprehensive labels and notes explaining the sketch are given. • Mechanical control system is indicated in detail. • The idea is critically evaluated with relevant strengths and weaknesses written down in detail. | 9 – 12 |
| 4 - 5 | <ul style="list-style-type: none"> • Develops an idea by drawing freehand sketches taking into consideration the design brief creative, relevant and most of the constraints and specifications. • Labels and notes explaining the drawing are included. • Mechanical control system is indicated in sufficient detail. • The idea is critically evaluated with most strengths and weaknesses written down. | 6 – 8 |
| 2 - 3 | <ul style="list-style-type: none"> • Develops an idea by drawing poor sketches taking little consideration of the design brief, constraints and/or specifications. • Basic labels and notes are included. • The mechanical control system is mostly inappropriate or incomplete. • The idea is critically evaluated with few strengths and weaknesses written down. | 3 – 5 |
| 1 | <ul style="list-style-type: none"> • Develops an inappropriate idea by drawing poor sketches with no consideration for the design brief, constraints and specifications. • No labels and notes included. • The mechanical control system is inappropriate, incomplete or non-existent. • The idea is not evaluated. | 0 – 2 |

**ACTIVITY 3: SELECTION OF DESIGN
GROUP ACTIVITY**

(20 minutes)

LO 1: AS 8

Marks: 6

- 3.5 Each individual will submit his/her sketch to their group. The group will then select the best design and/or modify the designs to come up with one final design. Write down the reasons for your choice. (6)

Rubric to assess selection of design

| LEVEL | DESCRIPTORS | MARKS |
|-------|--|-------|
| 6 - 7 | Choice is valid and reasons given are comprehensive, relevant and appropriate. The reasons are matched against the design brief, constraints and specifications. | 5 – 6 |
| 4 - 5 | Makes a good choice and reasons given are relevant. The reasons are mostly matched against the design brief, constraints and specifications. | 3 – 4 |
| 2 - 3 | Few reasons are given. The reasons have little correlation with the design brief, constraints and specifications. | 2 |
| 1 | One or no reasons are given with little correlation with the design brief, constraints and specifications. | 0 – 1 |

**ACTIVITY 4: MAKE: PLANNING
INDIVIDUAL AND GROUP ACTIVITY**

(40 minutes)

LO 1: AS 8; AS 9

Marks: 34

- 3.6 Each individual will prepare a detailed drawing of the model of the mechanical control system that will be used in the device. Use correct South African conventional drawing standards.

You need to:

- use a heading and labels;
- include dimensions;
- label on the drawing the materials you will be using to make the model of the mechanical control system;
- use arrows to how the cleat works. (10)

Rubric to assess detailed drawings:

| LEVEL | DESCRIPTORS | MARKS |
|--------------|--|--------------|
| 7 | Detailed drawings of the model are developed using an appropriate range of available media. Drawings clearly communicate the idea. Drawings have relevant headings and detailed labels and notes. Dimensions are realistic. Materials to be used in the model are labelled. Arrows are used to show how the cleat works. | 8 - 10 |
| 6 | Reasonably detailed drawings of the model are developed using a good range of media. Drawings communicate the idea. Drawings have relevant headings and labels and notes. Most dimensions are included and are realistic. Materials to be used in the model are labelled. Arrows are used to show how the cleat works. | 7 |
| 5 | Drawings of the model are developed using a range of media. Drawings communicate the idea. Drawings have relevant headings and labels and notes. Few dimensions are included. Most materials to be used in the model are labelled. Arrows mostly demonstrate how the cleat works. | 6 |
| 4 | Drawings of the model are developed using a limited range of media. Drawings communicate the idea. Drawings have headings and basic labels and notes. One or two dimensions are included. Some of the materials to be used in the model are labelled. There is an attempt to show how the cleat works by using arrows. | 5 |
| 3 | Basic drawings of the model are developed. Drawing has heading, but labels and notes are not sufficient to communicate the idea clearly. One or two dimensions are included. One material to be used in the model is labelled. No arrows are used. | 4 |
| 2 | Develops basic drawing of the model. Headings, labels and notes are scarce and uninformative. The idea is not clearly communicated. There are no dimensions. No materials to be used in the model are labelled. No arrows are used. | 3 |
| 1 | Develops an inappropriate drawing. Headings, labels and notes are inappropriate or not included. The idea is not communicated. No dimensions are included. Drawings communicate the idea. No materials to be used in the model are labelled. No arrows are used. Or no drawing is handed in. | 0 – 2 |

3.7 In your groups, develop a detailed **flowchart** to show the sequence of activities needed for the making process. (10)

Rubric for assessing the flowchart:

| LEVEL | DESCRIPTORS | MARKS |
|-------|---|--------|
| 6 – 7 | <ul style="list-style-type: none"> • A comprehensive flowchart is developed showing a detailed and logical sequence of activities. • The steps are clear, precise and easy to follow. • The flowchart focuses on the making process of the model. • The flowchart uses correct symbols. • No progression evident. • Approximate time needed for each activity is included, not exceeding 1 hour. | 7 – 10 |
| 4 – 5 | <ul style="list-style-type: none"> • A relevant flowchart showing a reasonably detailed and logical sequence of activities is developed. • The steps are clear and easy to follow. • The flowchart focuses on the making process of the model. • The flowchart uses mostly correct symbols. • No progression evident. • Approximate time for each activity is included, in total a maximum of 1 hour. | 5 – 6 |
| 2 – 3 | <ul style="list-style-type: none"> • A basic flowchart is developed. • Instructions are difficult to understand. • The flowchart focuses partially on the making process of the model. • The flowchart uses few correct symbols. • No progression evident. • A time schedule has been included but the allocation of time is not detailed and realistic. | 3 – 4 |
| 1 | <ul style="list-style-type: none"> • A simple flowchart is developed but the steps are not in logical sequence. • The instructions are not clear and are very difficult to understand and follow. • The flowchart does not focus on the making process of the model. • The flowchart does not use correct symbols. • No progression evident. • There is little or no breakdown of time allocated. | 0 – 2 |

3.8 In your groups list the materials that are needed for the model. (8)

3.9 In your groups list the tools that are needed to make the model. (6)

**ACTIVITY 5: MAKE
GROUP ACTIVITY**

(70 minutes)

LO 1: AS 10, AS 11, AS 12

Marks: 20

3.10 In your groups, construct the model according to your final design and follow the steps in the flowchart developed in Activity 4. If there are any changes to be made to the flowchart, these need to be recorded and reasons need to be given. Work safely and use the tools correctly. (20)

Your group will be assessed on the making process using the following rubric:

Rubric for the making process:

| LEVEL | DESCRIPTORS | MARKS |
|-------|--|---------|
| 6 – 7 | The group completed the model in the allocated time. The group worked safely and worked with the tools and materials with precision, control and efficiency. Measuring and checking procedures were used to monitor quality and changes. Flowchart was followed and changes with reasons were written down. There was little wastage of materials. Work space was left clean and tidy. | 14 – 20 |
| 4 – 5 | The group completed most of the model in the allocated time. The group worked reasonably safely and worked with most of the tools and materials with precision, control and efficiency. Some measuring and checking procedures were used to monitor quality and changes. Flowchart was mostly followed. Changes and reasons were written down. There was little wastage of materials. Work space was left reasonably clean and tidy. | 10 – 13 |
| 2 – 3 | Extra time (more than 30 min) was needed to complete the model. The group did not follow the correct safety procedures and some tools were not used correctly. Flowchart was not adhered to. Work space was left untidy. | 6 – 9 |
| 1 | The model was not completed. Safety procedures were not observed. Work space was left untidy. Measuring and checking procedures were non-existent. Flowchart was not followed. OR no making process occurred. | 0 – 4 |

ACTIVITY 6: EVALUATE THE PRODUCT
INDIVIDUAL AND GROUP ACTIVITY
(60 minutes)
EVALUATE THE PRODUCT
LO 1: AS 13, AS 14
Marks: 22

This activity will assess your individual ability to develop self-generated criteria and your group's ability to test and evaluate a product.

- 3.11 Individually, develop a list of criteria to assess the models. Then in your groups, develop a list of at least four criteria, derived from the individual inputs, that you will use to assess each group's model. These criteria must be linked to the design brief, constraints and specifications that you have developed.)

Rubric to assess self-generated criteria:

| LEVEL | DESCRIPTORS | MARKS |
|-------|---|-------|
| 6 – 7 | <ul style="list-style-type: none"> • Criteria are linked directly to the design brief, constraints and specifications. • Criteria are appropriate and relevant to the task. • Weighting of criteria is appropriate. | 4 – 5 |
| 4 – 5 | <ul style="list-style-type: none"> • Most criteria are linked directly to the design brief, constraints and specifications. • Most criteria are appropriate and relevant to the task. • Weighting of criteria is mostly appropriate. | 3 |
| 2 – 3 | <ul style="list-style-type: none"> • Few criteria are linked to design brief, constraints and specifications. • Few criteria are appropriate and relevant to the task. • Weighting of criteria is not appropriate. | 2 |
| 1 | <ul style="list-style-type: none"> • Only one criterion is given. • Criteria are not appropriate or relevant. • No weighting is apparent. • OR the criteria have not been filled in. | 0 – 1 |

- 3.12 In your group, using the criteria that you developed, evaluate the model of another group. Allocate 12 marks for the model. (12)
- 3.13 In your group, think of THREE areas, by referring to three different aspects of your completed model, that you would improve or modify to make a more effective or better quality end-product. Explain in detail by answering the question: 'If I ever had to make the model again, I would improve (what) ..., because (why) ..., by doing the following (how)' (5)

GLOSSARY:

| | |
|----------------|--|
| tills: | prepare soil to grow crops |
| strategies: | a long-term plan |
| drought prone: | likely to suffer from lack of water |
| device: | a tool or machine designed to perform a particular task or function |
| harvest: | gathering in crops |
| treadle: | a foot-operated pedal |
| discharge: | to emit or give off |
| manifold: | a chamber with several openings for receiving or distributing a fluid or gas |
| internal: | placed on the inside |
| debris: | pieces of something that have been broken down into smaller bits |
| irrigation: | the means of supplying water to land |
| sustainable: | able to endure, last a long time |